



JLG 450 SERIES

- Choice of models with up to a 15.5 m working height
- Fast boom and drive speeds improve work productivity
- Multiple simultaneous boom functions get you to the job quicker
- Proportional controls achieve smoother movement for operator comfort
- Excellent manoeuvrability for positioning of machine and platform
- Handle the roughest terrain with increased engine power

For more details check the JLG Technical Specification Guide or ask your local JLG representative.



Oscillating axle option for tough travel

Provides increased traction when travelling.



Easy to follow layout of controls

Console designed for ease of use and rapid positioning control.



Semi-track Option with Floating idler

Assists when travelling through mud, sand and snow.



Operator's Tool Tray

Provides a handy storage area for tools, fasteners and other work materials.



Articulating Jib*

Allows for greater versatility when positioning the platform around obstacles.

* Model 450AJ only.



Operator's Tool Tray

Provides a handy storage area for tools, fasteners and other work materials.

JLGEUROPE

JLG Industries (Europe), A Division of JLG Industries, Inc.
Kilmartin Place, Tannochside Park,
Uddingston, G71 5PH, Scotland.
Tel: 01698 811005
Fax: 01698 811055

www.jlg.com



ARTICULATING BOOM LIFTS

	450A 450 Series II	450AJ 450 Series II
Platform Height	13.72 m	13.72 m
Horizontal Outreach	7.47 m	7.47 m
Up and Over Height	7.67 m	7.67 m
Swing (non continuous)	360°	360°
Platform Capacity – Unrestricted	230 kg	230 kg
Platform Rotator (Hydraulic)	180°	170°
Jib – Overall Length	—	1.24 m
Jib - Range of articulation	—	145° (+78°/ -67°)
A. Platform Size	0.76 m x 1.83 m	0.76 m x 1.83 m
B. Overall Width	1.98 m	1.98 m
C. Tailswing (working condition)	Zero	Zero
D. Stowed Height	2.30 m	2.30 m
E. Stowed Length	6.50 m	6.53 m
F. Wheelbase	1.98 m	1.98 m
G. Ground Clearance	0.36 m	0.36 m
Gross Vehicle Weight ¹	7,000 kg	7,100 kg
Maximum Ground Bearing Pressure	5.3 kg/cm ²	5.48 kg/cm ²
Drive Speed 2WD	5.6 km/h	5.6 km/h
Drive Speed 4WD	7.2 km/h	7.2 km/h
Gradeability 2WD	30%	30%
Gradeability 4WD	45%	45%
Tyres (Foam Filled)	12 x 16.5	12 x 16.5
Axle Oscillation ²	0.20 m	0.20 m
Turning Radius – Inside	1.73 m	1.73 m
Turning Radius – Outside	4.27 m	4.27 m
Diesel Engine (Deutz F3M1011F)	35 kW	35 kW
Fuel Tank Capacity	62.5 L	62.5 L
Hydraulic Reservoir	113.6 L	113.6 L
Auxiliary Power	12V DC	12V DC

¹ Certain options or country standards will increase weight.

² Optional on models 450A and 450AJ.

Specifications may change to meet country standards or with the addition of optional equipment.



JLG MODEL 450A (450 Series II)

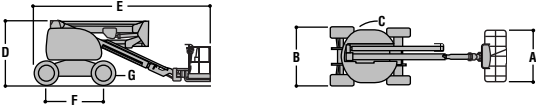
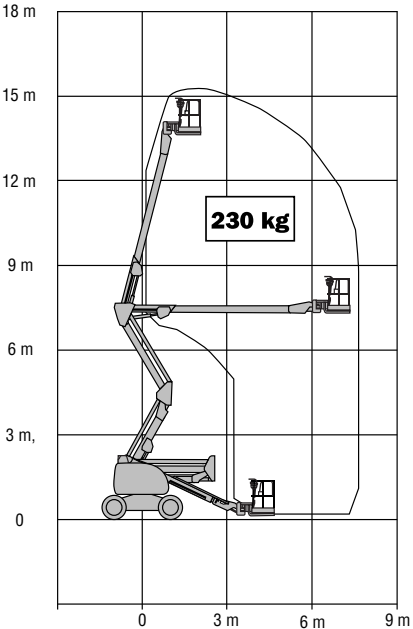

JLG MODEL 450AJ (450 Series II)

